

*caravaning*



Fresh water tanks  
Waste water tanks





# FRESH WATER / WASTE WATER TANKS

### 80 LTR. WATER TANK



Code: 7453

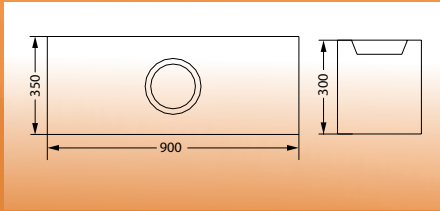

### 126 LTR. WATER TANK



Code: 7454

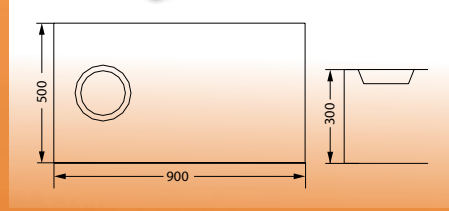

### 156 LTR. WATER TANK



Code: 7452

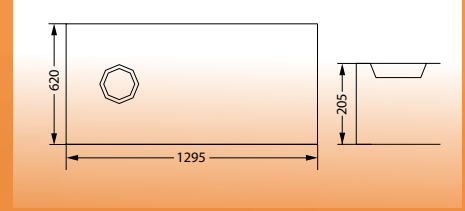

### WATER TANK BAIÁ



Code: 1304000

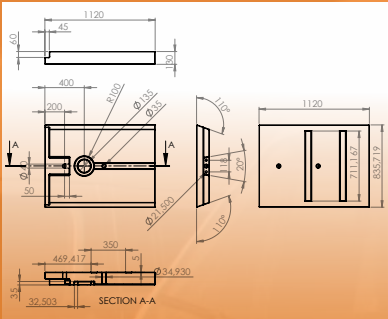

### WATER TANK VARIO 100 L



Code: 3520016

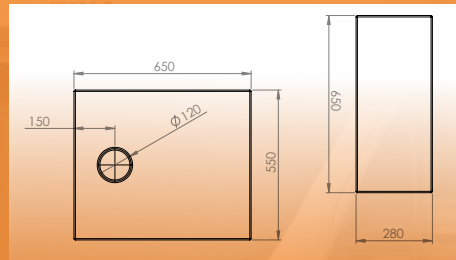

### ISOLATION BOX 100L



Code: 7474

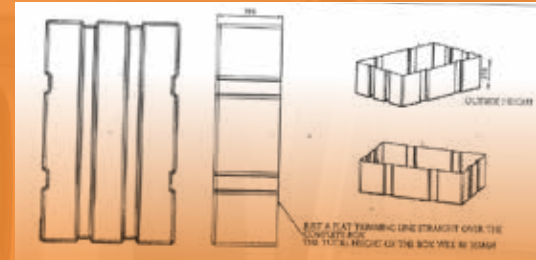

### WATER TANK ATOL 115 L

Code: 3520017

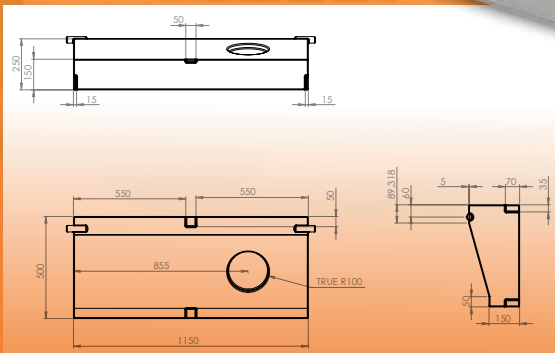

### WATER TANK ATOL 95 L

Code: 130030789

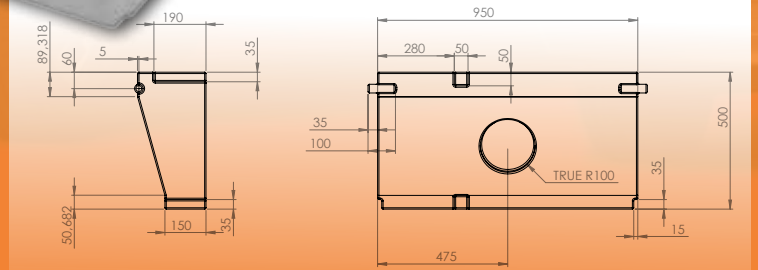

**WATER TANK  
CANCUN 70 L**



Code: 7450

**WATER TANK  
MARINO 110 L**



Code: 7526

**WATER TANK  
SOLEO 40 L**



Code: 7461

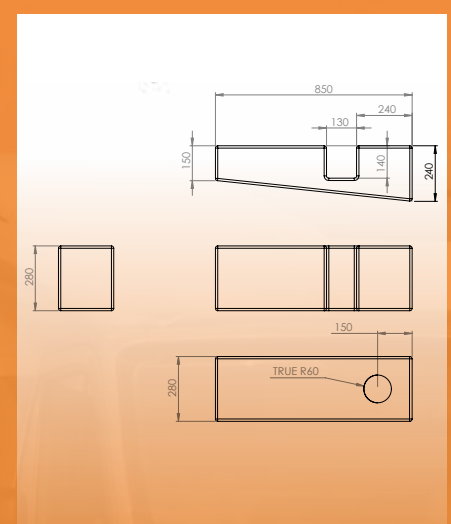
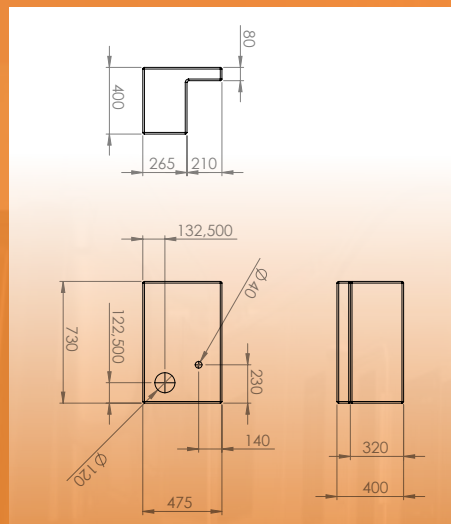
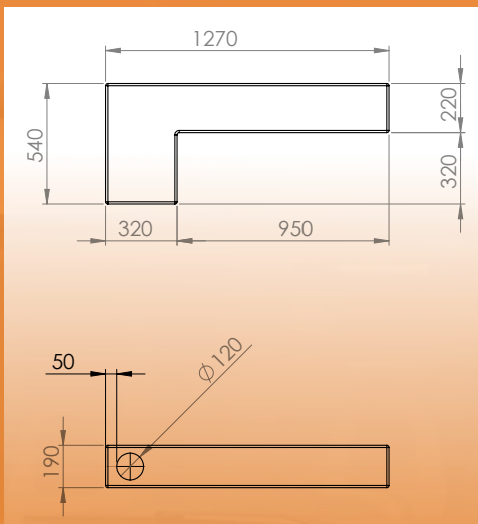

**WATER TANK  
ANDALU 75 L**

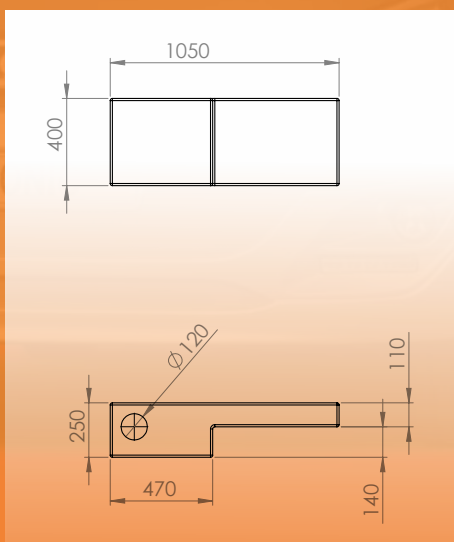

**WATER TANK  
MALIBU 45 L**

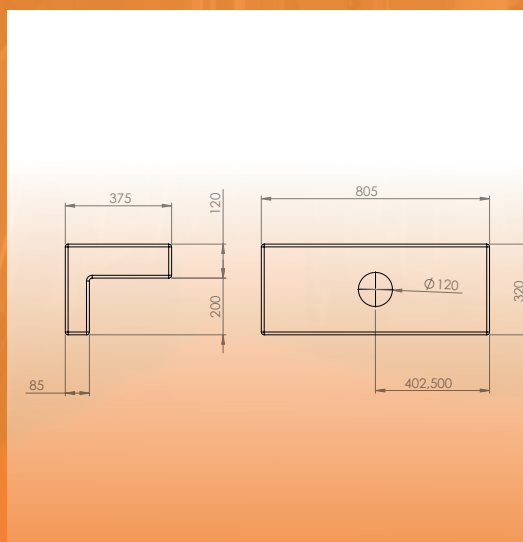

**WATER TANK  
CANCUN 80 L**

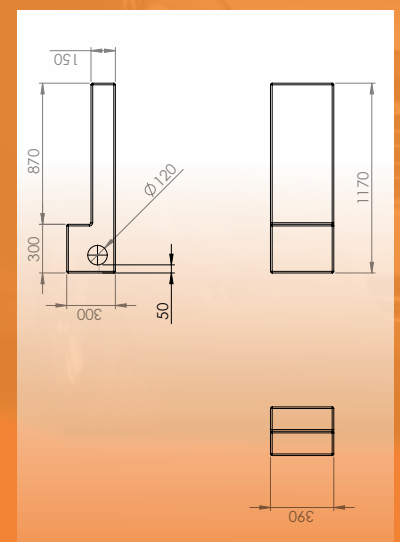





## CUSTOM MADE TANKS FOR MOTORHOMES AND CARAVANS MANUFACTURERS

### REFERENCES



The ROTO Group comprises 13 companies with manufacturing facilities located in four European countries. The company is in private ownership and has been active in the domestic market as well as foreign markets for over 40 years as a successful manufacturer of plastic material products with the reputation of a reliable business partner.

The production of over 4,000 products with a volume capacity of up to 25m<sup>3</sup> and the annual processing of over 3 million kilos of polymers make ROTO one of the leading European companies using the rotomoulding manufacturing technology. Companies in the Group have recorded a 20% annual growth in revenues, which is the result of constant product development, investments in the update of manufacturing capacities, and good sales results recorded in all continents of the world.

Through our own product development department and manufacture, we keep expanding our offering, and developing new products every year.

The Roto Group's competitive advantages are based on differentiation and flexibility, innovation brought to the marketing strategy, and good technological support offered to customers. We fill in the market gap occurring when a product is, at its stage of life cycle development, translated into mass production. Through functional design we increase the added value of our products and we also increase the quality of manufacture, offer sales services, fit plastic products with components that offer an integral solution to the problems tackled by our customers, and use intelligent materials and modern technologies in the process of manufacture.

### CERTIFICATION

#### FRESH WATER TANKS

Are certificated according to standard DVGW W270, KTW Zulassung (DIN 2001).



#### ROTO d.o.o.

Murska Sobota, SLOVENIJA

Tel: +386 (0)2 52 52 164

Fax: +386 (0)2 52 52 171

industry@roto.si, www.roto-industry.si